

BIGTIMECLOCKS® BHC®

MODEL XL-46R-100

**TIME OF DAY
COUNTDOWN / UP
DIGITAL WALL CLOCK**

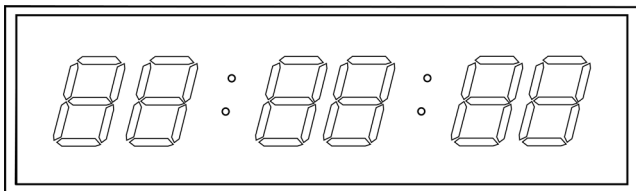

What's in the box

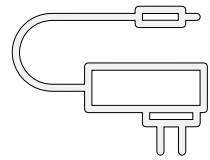

1X Power supply

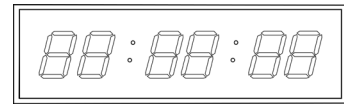

1X Digital clock



1X Remote control

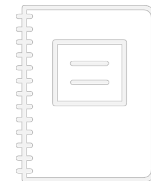

1X User's guide

1. Overview

BigTimeClocks® XL-46R-100 is a 4" numeral / 6 digit indoor wall clock which displays hours, minutes and seconds. The clock must not be permanently installed outdoors but can however be used for outdoor events if not exposed to water/rain.

Model XL-46R-100 is operated only with the supplied remote control model REM-XL46 (spare remote controls are available on demand, please contact Customer Service- see page 4 for contact details).

Model XL-46R-100 is designed to be either wall mounted (see figures 2 & 3) or mounted to tripod model #300 (see figure 4).

Figure 1

Clock dimensions

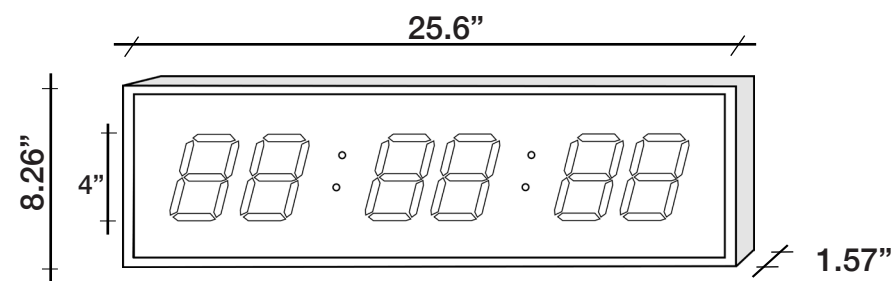

NOTE: Model XL-46R-100 is a plug-in digital clock. A small battery is included in the clock for backup purposes in order to maintain clock functions in the background. The battery will however not illuminate the display. The clock will remain on time when power resumes. Model XL-46R-100 is exclusively operated with the remote control supplied with the clock.

Figure 2

Rear view of clock

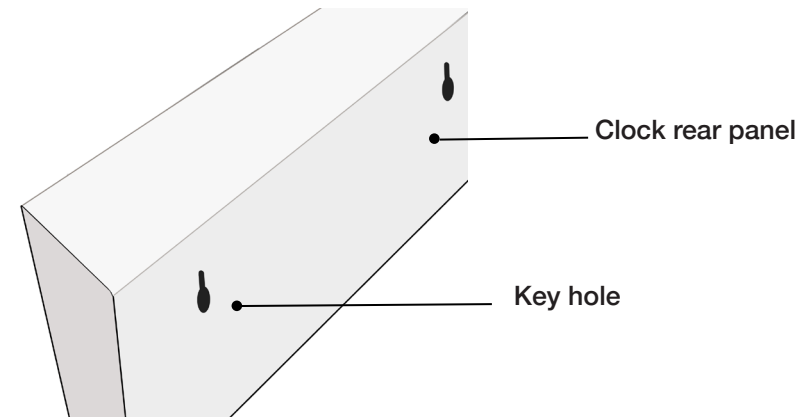

2. Setup

2.1 General instructions

Use remote control keys to select function.(clock, countdown/up, interval timer, date display).

- Press EDIT key to setup function,

Use the left/right arrow keys and number keys to set target time. (Left/right arrow keys to navigate between

blinking digits to be set, number keys to set the target time).

- Press EDIT key again to exit with saved setting. Or EXIT key to exit without saving.

MEMORY KEYS: After setting a function value, press a number key (number key 0-9) to assign the function to a particular number key for direct recall if desired. Users can define preset values for countdown, count up,and interval timer functions.

2.2 Time of day

PRESS key to display time. (HH:MM:SS format is the default display).

- Display 12-hour or 24-hour (military time) format by pressing 12Hrs or 24Hrs keys.
- Press EDIT key to enter setting mode and press EDIT key a second time to save and exit setting.

2.3 Countdown

Press to enter countdown timer mode and timer will display HH:MM:SS "99 59: 59".

- Set the target countdown time by arrows & number keys following the general setting instructions above.
- Press OK to start, stop, or to resume the timer function.
- Press the +/- 10s key on the remote to activate/deactivate a 10 second "pre" countdown

2.4 Count up

- Press to enter count up timer mode and timer will display “00:00 00”
- Set the target count up time by using the arrows & number keys following the general setting instructions above
- Press OK to start, stop, or to resume the timer function
- Press the +/- 10s key on the remote to activate/deactivate a 10 second “pre” count up

2.5 Stopwatch

- Press key to enter the stopwatch function and the timer displays “F3 00 00”
- Press OK to start, stop, or to resume the stopwatch timer

2.6 Auto repeat

- Press to activate the auto repeat feature. The clock will beep twice indicating this function is active. Only 1 beep indicates the function is inactive. Is so, press the key again until the clock beeps twice
- At the end of each loop, the clock will beep once (unless muted)
- The 10s preparation time (+- 10S key on remote can be used while auto repeat is activated)

2.7 Negative counting

- Press RT to activate negative counting. The clock will beep twice indicating this function is active. Only 1 beep indicates the function is inactive. Is so, press the key again until the clock beeps twice
- At the end of a countdown, the clock will beep 5 times and will start blinking and counting upwards. Beeping can be muted by pressing the mute key on the remote control
- Auto repeat and Negative counting cannot be activated simultaneously. When attempting to do so, negative counting has priority over auto repeat (negative counting will disengage auto repeat)

2.8 Interval timer

- The Interval Timer is for workout & rest interval timing (max 99 rounds). If 2 red dots are on fast blink, it is workout timing; otherwise it is rest time timing. One beep when workout time ends, and two beeps when rest time ends
- Press the INT key to enter the interval timer function and the clock displays “XX. XX .XX”
- Press EDIT key to set the repeating rounds
- Press EDIT key a second time to set workout time and EDIT key a third time to set the rest time
- Press EDIT key a fourth time to exit with saved setting. Or EXIT key to exit without saving
- Press key to decide whether the time will count up or down

2.9 Date display

- Press the F2 key to enter time display mode. Data shows: day of week, day of month, and month (E.g. 1_15 6 stands for Monday, June 15)
- Press EDIT to enter setting mode. Data shows year, month and day of month. Enter data with number keys and press the EDIT key a second time to save and exit setting

2.10 Notes

- Please stop any function in progress before changing to another timer function
- The remote requires 2 x AAA batteries
- Please do use the original power adapter to avoid any damage to the clock

3. Wall mounting

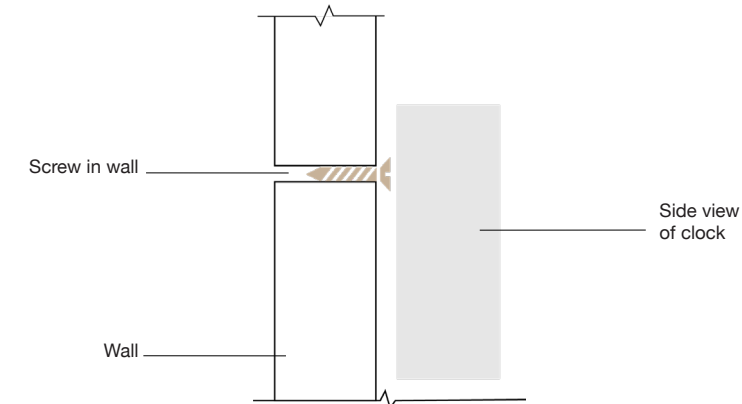

4. Remote control

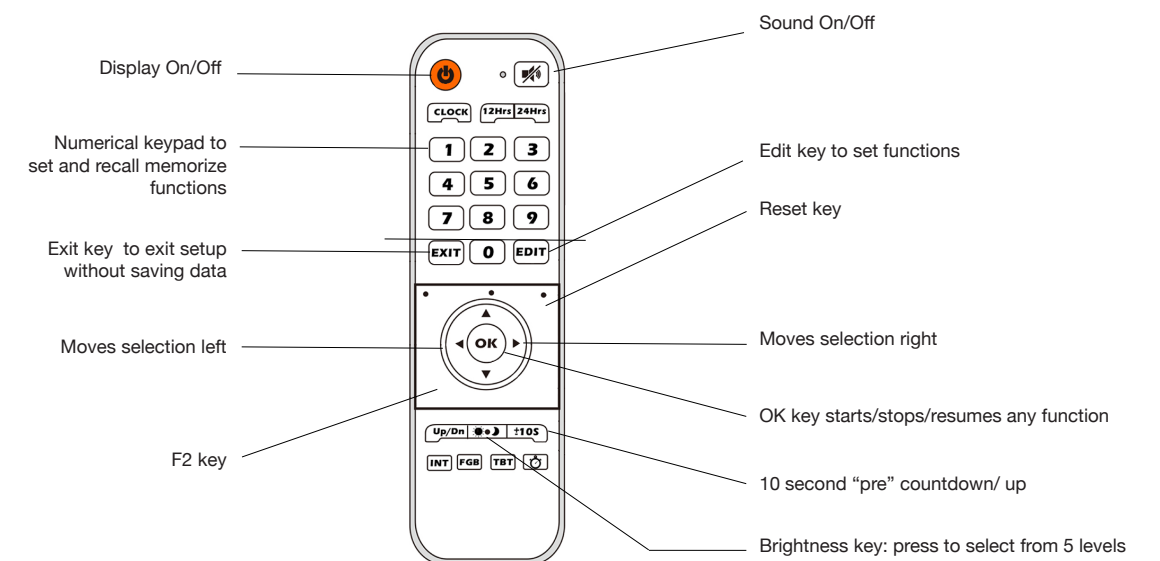



EZCLOCKS LLC.,
8565 S Eastern ave, Suite 150,
Las Vegas NV 89123
Tel: (702) 726 9030
www.bigtimeclocks.biz